

Fixed Height Gantry Crane

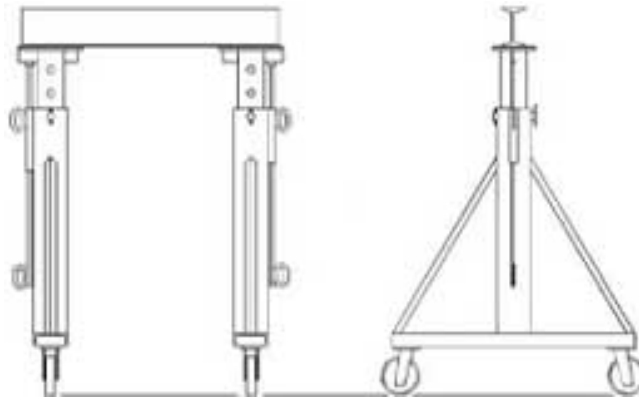

Telescoping Gantry Crane

MODEL NUMBER: _____
SERIAL NUMBER: _____
CAPACITY IN TONS: _____

Bushman Equipment, Inc.
262-790-4200, 800338-7810, Fax 262-790-4200

www.Bushman.com
custinfo@bushman.com

SAFETY INFORMATION

Read all the instructions in this Owner's Manual and any other manual, which accompanies this equipment before assembling or using this equipment.

Read and obey all the warnings and other safety information attached to the gantry crane before assembling or using this equipment.

Keep all warnings and safety labels attached to the equipment and legible. If the safety labels become damaged or unreadable, call the factory for free replacements.

The equipment must only be operated on a level, clean, hard flat surface.

The equipment must be operated in a location that will allow the operator to stay in a safe position, not under or near the load on the equipment.

The equipment must be operated from a position that will not be hazardous to the operator or present hazardous conditions to the operator.

LOAD CAPACITY

Do not use your gantry and/or accessories to lift more than their rated capacity. Capacity ratings are based on new equipment. Age, dirt, improper maintenance, and daily wear will reduce the operating capacity of the gantry and/or accessories. Do not continue operation of any equipment damaged by overloading.

Never attach a load greater than the capacity of the equipment. Never use two pieces of equipment to lift a load greater than the rated capacity of a single piece of equipment. A shifting load may place the weight of the entire load on either piece of equipment, causing one to fail.

Apply the load evenly. Do not jerk or bounce a load or allow a load to swing. Avoid violent motions, shock loads, or any other loading for which the equipment is not rated. This type of loading requires equipment of greater capacity.

Never exceed the rated load capacity of the smallest component being used in the system. Review the capacity of each component in the system and load the system to the smallest capacity only.

Before operating, check each component of the equipment system for cracks, breaks, distortions, deformed parts, improper adjustment, loose parts, or other unsafe conditions. Discontinue use of the equipment if any unsafe condition is found. Never leave a suspended load unattended.

This equipment is not made to lift people or to lift loads over people. Do not walk or work under a suspended load or allow anyone else to do so.

Always center the hoist over the load before operating the equipment.

When the gantry is used with an electric hoist or other electrical accessories, make sure the electrical ground wires are installed per the electrical code for safety. Ensure that

the wires are always connected when the equipment is in use. Consult the local electrical code for regulations concerning connecting and operating electrical equipment.

For safe lifting, use a sling or other approved safe lifting device that is securely attached to the load.

Be sure the load attachment is properly seated in the saddle of the hook. To avoid tipping the load, balance it properly before handling.

PLEASE READ PRIOR TO ASSEMBLY

The assembly instructions in this manual are provided as a guideline only. The manufacturer shall in no way be held liable for any accident or injury incurred during or because of the assembly of this piece of equipment.

For information concerning product warranty, please see the statement at the end of this manual.

WARNING LABELS

This piece of equipment is shipped with the following warning labels attached. Please examine the shipment upon receipt. If any of these labels are missing, please contact the factory for replacement immediately.

The manufacturer is in no way liable for any accident or injury incurred during the use of this equipment without the appropriate warning labels.

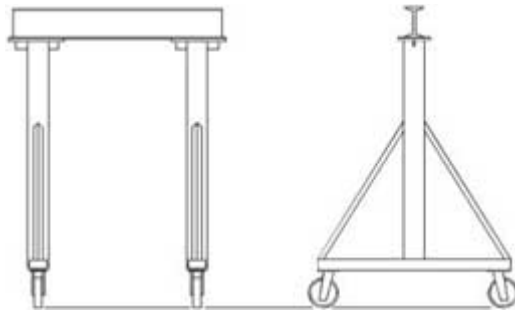

FIXED HEIGHT GANTRY:

1. CAUTION: Lock Wheels When In Use
2. CAUTION: Do Not Move Gantry While Loaded
3. CAUTION: Do Not Exceed Capacity

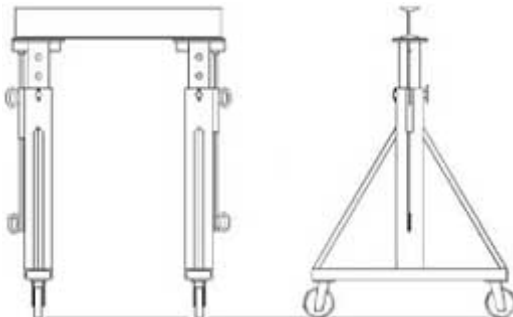

TELESCOPING GANTRY:

1. CAUTION: Do Not Raise Load With Cable Come-A-Longs
2. CAUTION: Do Not Move Gantry While Loaded
3. CAUTION: Lock Wheels When In Use
4. CAUTION: Do Not Exceed Capacity

RESOURCES REQUIRED FOR ASSEMBLY

- Three persons, a mechanic experienced in assembly and two people to help in the assembly process
- Hoist, forklift, crane, or other device capable of safely lifting one ton to a height of 12 ft.
- Lifting sling
- Tapered drift punch for hole alignment
- 24-inch pry bar
- Combination wrenches
- Zero to 100-foot-pounds torque
- Wrench and socket set
- Safety equipment including hard hats, barricades, and whatever else is necessary to provide a safe working environment.

ASSEMBLY INSTRUCTIONS

Note: FOR TELESCOPING MODELS, REFER ALSO TO ADDITIONAL INSTRUCTIONS ON PAGE 4.

1. Any person assembling the gantry crane must read the following instructions. The assembly of the gantry crane requires three people. Extreme caution must be taken during assembly to prevent accidents caused by falling of heavy parts.
2. With the column (Item 3) lying flat, assemble the casters (Item 9) to the base tube (Item 1) using the smaller diameter bolts, lock washers, and nuts in the supplied hardware box. Insert the bolts from the inside of the tube out and then into the caster mounting plate. Add the lock washer (Item 15) and nut (Item 14). Without lubricant, the experienced mechanic should tighten these bolts to 55 to 60- foot-pounds torque each. If assembling a telescoping model, refer to that page.
3. Lay the I-beam (Item 5) on the floor with holes facing toward top of column assemblies.
4. Two people will raise one end of the column assembly base tube (Item 1) vertically until one end of the base is pointing up. One person should guide and steady the base and another person should guide and steady the top of the column as it is carefully positioned against the matching bolt holes in one end of the I-beam.
5. Align the bolt holes in the mounting plates at the top of the column and on the I-beam. Insert the larger diameter supplied bolts into the holes, add a lock washer and nut, and finger tighten only. Without lubrication, tighten these four bolts to 55 to 60- foot-pounds torque each. The base must be held steady while all bolts are tightened.
6. Repeat steps four and five for the remaining leg.
7. The gantry is now ready to be raised to its normal upright position. Carefully lift the gantry using a hoist, forklift, or other means with sufficient lifting height and capacity. Stand clear as the gantry is being raised.

ADDITIONAL NOTES FOR ASSEMBLY OF TELESCOPING GANTRY MODELS

T-1. Prior to performing Step 3 above, insert both upper columns (Item 4) into the lower column assembly (Item 3) fully and pin them in place with the pin assembly (Item 6). Be sure the pin is locked with the cotter key (Item 2). The pins must be in place at all times except during height adjustment. Refer to drawing [GCT-197-D](#) attached.

T-2. After raising the gantry into a vertical position (Step 7), attach the cable come-a-longs provided to the chain link come-a-long anchors (item 12) on each leg, (attach cable end hook of come-a-longs to upper loop.) See the "Come-a-Long Operating Instructions" attached.

Note: For ease of operation and reaching the come-a-long, attach the hook on the come-a-long body to the lower anchor and the cable end hook of the come-a-long to the upper anchor.

T-3. Note: DO NOT USE CABLE COME-A-LONGS TO RAISE YOUR LOAD. Come-a-longs are used only to raise the beam (Item 5) to the desired height PRIOR to lifting any load.

BE SURE TO REINSTALL THE LOCK PIN ASSEMBLY (Items 2 and 6) AFTER RAISING THE BEAM TO THE DESIRED HEIGHT.

ACCESSORIES

The gantry, by itself, is a movable supporting structure. To make the gantry crane functional as intended, more components are needed. These additional components are a trolley, hoist, and rigging equipment such as a nylon sling. The capacity of these additional components should be the same as the rated capacity of the gantry and should be used according to the manufacturer's instructions and recommendations.

A qualified person should install the hoist and trolley according to the manufacturer's instructions. Do not modify the gantry members by drilling holes for the attachment of any component, or by welding to the gantry. This will weaken the gantry's lifting capacity.

OPERATING INSTRUCTIONS

The gantry crane is intended to provide a portable overhead beam for lifting a load when a fixed beam is not available. The load should be moved from one point to another by moving the trolley back and forth along the gantry I-beam, while the gantry crane is itself stationary. Use extreme caution when attempting to horizontally move a load by moving the entire gantry crane, this method is NOT RECOMMENDED. Come-a-longs are used only to raise the beam (Item 5) to the desired height prior to lifting any load.

BE SURE TO REINSTALL THE LOCK PIN ASSEMBLY (Items 2 and 6) AFTER RAISING THE BEAM TO THE DESIRED HEIGHT.

It is always necessary to center the I-beam, trolley, and hoist directly above the balance point of the load when operating the gantry crane. The only purpose of the hoist is to move the load straight up and down and to suspend the load. Do not operate the hoist to move in any direction other than straight up and down. Any hoist will produce a mechanical force great enough to tip over the gantry crane if not properly or carefully operated.

When lowering the load into its desired position, it is important that the gantry I-beam, trolley, hoist, and load be positioned directly above the intended resting spot for the load. The load must be moved only directly down to its desired location. Never force the load off to the side or end of the gantry when it is being lowered. When moving the load along the length of the overhead beam with the trolley, make sure the caster wheels are locked and that all movements are made slowly and with care. Do not allow the load or trolley to make a forceful or violent contact with either end of the gantry or with other obstructions.

When moving the load with the trolley, make sure the trolley track (bottom flange of the I-Beam) is free of any obstruction. Be sure the only force applied to move the trolley is in the direction of the length of the trolley track. **DO NOT APPLY SIDE FORCE DURING THE MOVE.**

The load attachment should be suited to the material being lifted. It should securely retain the load in the desired position for the lifting operation. All load attachments must be inspected on a regular basis for possible deterioration. Load attachments must always be used in the fashion prescribed by their manufacturer and must be kept in excellent repair. Never attach a load to the hoist by using the hoist chain or rope as a substitute for a proper load attachment sling.