



## Applications for Tong Grabs in the Steel Industry

Presented at the 1998 AISE Annual Convention

The tong grab has been used in the steel and iron industry for the last two centuries and by early civilizations as far back as the Roman Empire. Because of the tong's simplicity, suitability for use in the worst mill duty environments, and long term reliability, the tong has a wide appeal to a large spectrum of users. Steel mills utilize tongs because they can be designed to withstand significant heat, are not affected by electromagnetic interference, have low maintenance requirements and can withstand significant shock loading. Service centers or fabricators like the fact that the tong requires few operators, and can be used at various locations around the plant without concern for electrical or special hook needs. The small end-users embrace the tong for its low cost, flexibility and durability. With minimum (or zero) down time on the process line a major goal of most organizations, the design characteristics of the tong grab make it an appropriate tool for many applications.

Although the lifting device is an important tool for many production line processes, the wrong application or improper use of a tong grab can cause significant property damage and even the loss of life. The core themes of this paper will be identifying the right tong grab for the application, describing the different design characteristics that should be employed, and maintaining the tong grab properly during the life of the device. This paper will concentrate on tongs that are activated by gravity (no motorization.)

### MECHANICS

The tong is a type of machine that modifies and transforms input forces into desired output forces. Although tongs come in a multitude of shapes and configurations, most of them can be broken down into a simple "four-bar" linkage for analyzing their movement and forces. Although each material handling application will require specific analytical calculations to determine the proper structural configuration of the tong, a simple static analysis of a tong will show important relationships that can be helpful when selecting the proper tong for your application. Figure 1 shows a simple pressure type tong grab; the specific loads on the links have been exploded for illustration. Our goal is to perform a summation of moments around the center pin (point Z) to determine the equation for the force on the load ( $F_x$ .)

Assume: Load (L) = weight of grab + load weight

From the free-body-diagram of the upper link:

$$P_y = L/2$$

From the free-body-diagram of the lower link:

$$P_y = F_y \text{ and from above } P_y = L/2 \text{ so } F_y = L/2$$

$$F_x = P_x$$

$$\sum M_z = F_x A - F_y B - P_y C + P_x D$$

$$0 = F_x A + F_x D - L/2 B - L/2 C$$

$$F_x (A+D) = L (B + C)/2$$

$$F_x = \frac{L (B+C)}{2(D+A)} \quad \begin{array}{l} \text{("X-Links")} \\ \text{("Y-Links")} \end{array}$$

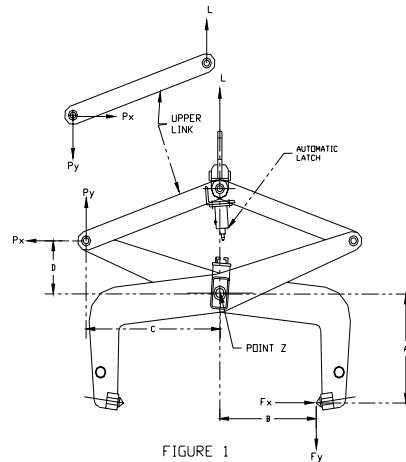

FIGURE 1

Based on this equation, we can formulate very important relationships on the movement of a tong grab:

1. As the magnitude of the X-Links increases with respect to the Y-Links, the gripping force will increase. This is the same principle that is exemplified by a pair of pliers. The link between the claws and handle is small, while the distance from the claws to where your hand closes the handle is much longer. This distance translates into a moment arm and creates the mechanical advantage or gripping force. This principle is the basis for the design of the vertical rim grab, which may have a gripping force of 5 to 6 for mill duty applications.
2. It is important to remember that X-Links and Y-Links are interdependent, and that the gripping force must stay high enough to prevent the loss of the load. This relationship explains why the grab's headroom increases when the tong is designed to lift a wider variation in widths. As the links swing, more headroom is required (longer Y-Links) which in turn requires more tong overall width (X-Links) to keep the gripping ratio high enough.

As shown above, the magnitude of the gripping force on the load ( $F_x$ ) can be determined by a static analysis. This value should not be confused with the "grip ratio" that is defined in ANSI B30.20, "Below-the-Hook Lifting Devices," Section 20-0.3 as "the ratio of the sum of the horizontal forces on one side of the load to the live weight of the load." The equation is:

$$\text{Grip Ratio} = F_x / \text{load}$$

Another important set of interactive forces to remember are the friction forces at the gripping point of the tong. From Mark's Standard Handbook for Engineers, Section 3.2, we can write the equations for friction based on Figure 1:

$$F_R < N f_o \quad \text{for bodies in a static condition}$$

Where:  $F_R$  is the force parallel to the surface

N is the force normal to the surface  
 $f_o$  is the coefficient of static friction

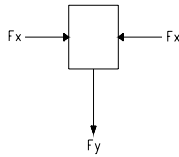

FIGURE 2

Substituting our variables creates (Figure 2):

$$F_y < F_x f_o \quad \text{for the load to be handled safely.}$$

Selecting the proper material for the pads of the tong is a very important part of the design of a grab. Sufficient margin in the above equation must be maintained to prevent loss of control of the load. Coefficients of friction are sensitive to atmospheric dust and humidity, oxide films, surface finish, temperature, vibration, and the extent of contamination. In many instances the degree of contamination is perhaps the most important single variable. Within the steel mill environment there is a distinct possibility of contamination of the pads and thus, a coefficient of friction that is hard to predict.

All of the pins, links, bails and other components of the tong should be analyzed based on the design capacity of the tong. ANSI B30.20 provides the following guidelines: "A lifter (tong) shall be designed to withstand the forces imposed by its rated load with a minimum design factor of 3, based on yield strength, for load bearing structural members." The designer needs to evaluate the environment that the tong will be immersed in, including heat, shock loading, and cycle time. For tongs that experience a high cycle time in a mill duty application, the designer may elect to increase the design factor to as high as 5, with consideration of shock loading of 150% or more. Due consideration must be given to the pivot points to ensure that the correct bushings are incorporated into the design with attention to the friction surfaces between the pins and links.

## TYPES OF GRABS

There are three basic configurations of tongs: supporting, gripping and pressure. They are illustrated in Figure 3.

*Supporting Tong* – This tong is identified by lifting feet that support the load and maintain it on a horizontal lifting plane. The load is usually a constant size and supported with dunnage to allow the tong's feet to slip under the load. The gripping force (the force that the tong exerts on the load) is minimal, so this lifter is excellent for loads which should not be marred by permanent indentation or loads which have an irregular shape but maintain a flat bottom. The supporting tong allows for a very tall load, while minimizing additional head height, since the gripping force is very small (see Relationship #1 in the Mechanics section.) Examples of loads that this type of lifter would handle include boxes, crates, bins and containers.

*Gripping Tong* – This tong is identified by the way it grips the material around the outside diameter with additional support provided by the tongs extending beyond and below the center of the load. The load is usually a coil, roll tube or other cylindrical load. The diameter range may vary by approximately 25%, while the variation in length is generally unlimited. The gripping force is minimal, so these tongs are ideal for materials that are susceptible to damage. Specially

contoured pads made with rubber or brass can be designed into the arms to protect the load and keep it stable during handling.

*Pressure Tong* – This tong is identified by the pads penetrating the load or providing sufficient surface friction to maintain a safe hold during handling. The gripping force of this type of tong is usually very high, so the loads tend to be very rigid structures such as metal ingots, slabs, or concrete highway barriers. This type of grab is used in many mill duty applications to handle hot, in-process material. These grabs come with a very large array of pads that establish the necessary coefficient of friction to safely handle the load.

Pressure grabs have also been used successfully in the garment industry to lift soft sided loads such as cotton bales or bolts of material that conform to the grab's pads and return to their original form after the tong has released the load.

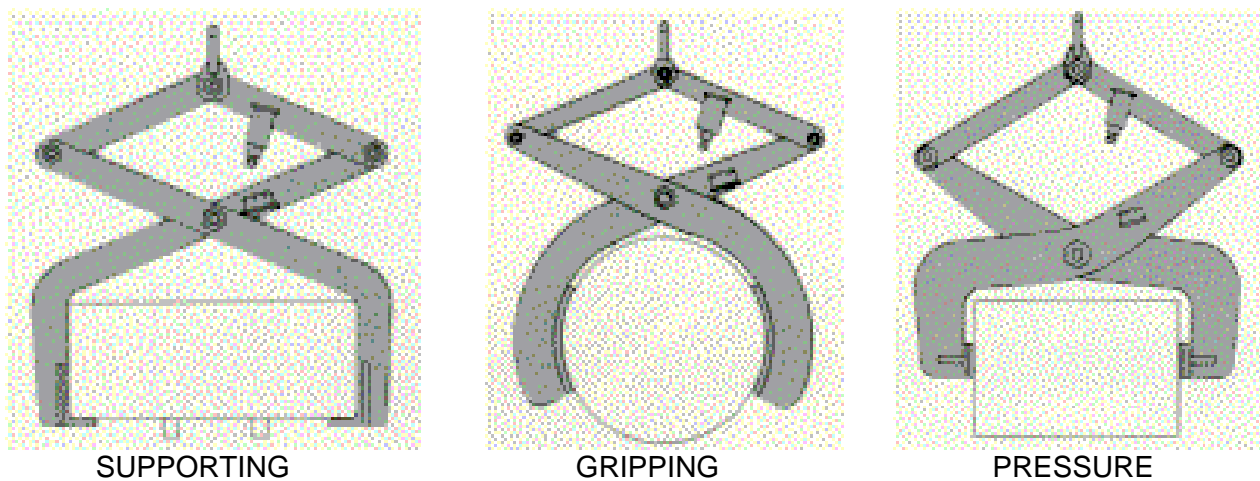

FIGURE 3

### MECHANICAL ATTRIBUTES

When selecting a tong, there are many different mechanical components that should be evaluated for their proper application. One of the most common attachments on a tong is the latch, either automatic or manual. An operator activates the manual latch at the appropriate time. In many cases it is a metal catch that holds the tong grab open between cycles. The automatic latch allows the clamping mechanism to operate without manipulation by an operator. This provides some degree of added safety since it eliminates the need for the arms of a human to be in proximity to potentially moving machinery. Many automatic latches work on the principle of a piston that moves vertically with the tong. On alternating cycles, the piston is rotated by a cam mechanism. On the first cycle with the grab resting on the load and the hoist tension released, the latch will rotate and disengage from a catch and lock open. The hoist is raised and the tong will clamp onto the load. To release the load, the grab is lowered and the load is placed on the ground to release tension in the latch. The latch will then rotate to engage in the catch and lock closed. This will hold the tong in the open position, and the hoist can be raised to remove the grab from the load.

The interface between the tong and the load is the focus of a multitude of decisions and problems. For a supporting tong, the decisions are minimized since the load rests on the tong pads and friction or grip ratios are not a major consideration. Gripping ratios may be as low as  $\frac{1}{2}$  to 1 for this

type of tong. The designer should evaluate the horizontal length of the supports to ensure that the load is stable. The edges of the material being handled must be able to bear the entire weight of the load to prevent rounding the corners and dropping the load. The designer should also evaluate the width of the load and its tendency to sag; if the load deforms excessively, the load may slide out of the tong.

The majority of gripping tongs are equipped with curved plates of varying dimensions to handle different cylinders, pipes and other circular loads. There is a maximum and minimum diameter roll that can be lifted with each grab. If the span of diameters of the different loads is too large, the tong will drag on the floor or adjoining rolls when closing and will slide on the floor when opening. The ratio of small to large roll diameters should generally not exceed eight-tenths. For example, a single gripping tong could handle pipe from 10 to 12 ½ inches in diameter. The headroom and grip may be increased and this ratio may be reduced, but with a resulting increase in material costs and lifter weight. The curvature of the pad should be ½ of the diameter of the largest load that will be handled by the tong. This will help maximize the contact area between the tong and the load. Some grabs are equipped with pivoting pads to minimize the width of the grab and provide a better lead-in when setting the tong on the load. If the tong has been designed correctly with part of the tong extending below the horizontal center line of the load for support, grip ratios can be as low as ½ to 1, but 1 to 2 is the usual grip ratio.

The pads or interface surfaces on a pressure tong come in a multitude of sizes, shapes and configurations. Figure 4 shows a small cross section of pads that are available. The designer must take extra time to ensure that the grab has sufficient grip ratio to securely hold the load under all atmospheric and dynamic conditions. When distortion of the load is acceptable, the use of interfaces that penetrate the side of the material is preferred since the load is actually supported in addition to the friction force ( $F_R$ ) created by the horizontal force ( $F_x$ ). Replaceable pins that fit into the pads can be selected based on the temperature and yield strength of the load material that will be penetrated. Hardened alloys or tool steel are common materials to use in the manufacturing of pins. There should be 1/16 to 1/8 inch of shank available for biting into the load at all positions. Assuming the vertical force ( $F_x$ ) is 0°, the points should be designed so that the angle of impact does not exceed 20° or -10° from the vertical. Grip ratios should exceed 1 to 1 for applications in which points penetrate the load; ratios of 2 or higher for straight friction lifting. As shown in Figure 4, there is an endless array of materials that can be selected for the pads. The pads should be designed to be removable to allow replacement as a result of wear.

## **MAINTENANCE**

As discussed in the opening paragraph, the simplicity of the tong leads to minimal maintenance requirements. The manufacturer should provide details on the different types of periodic maintenance actions that should be performed on their tong. The owner should then establish a preventive maintenance program for each individual tong based on these recommendations (ANSI B30.20, Section 20-1.5.1.)

One item on the preventive maintenance program might be lubrication of the tong if grease fittings are provided. Consult the manufacturer before lubricating your automatic latches; greasing some automatic latches might inhibit the piston movement and cause the latch to malfunction. Other items on the preventive maintenance program might be replacement of pads or points, cleaning and inspections.

## **INSPECTIONS**

ANSI B30.20, Section 20-1.3 provides specific requirements for inspections of below-the-hook lifting devices. The inspections are broken into two parts, frequent and periodic. The frequent

inspections are visual inspections that happen daily, weekly or monthly based on the level of service of the tong. The periodic inspection is a documented inspection that occurs quarterly, semiannually, or annually, based on the level of service of the tong. Each inspection is looking for damage, evidence of malfunction or deficiencies of the tong. The following guidelines list specific items that you should look for during your inspections. They are based on the requirements of ANSI B30.20.

- *Structural deformation, cracks, excessive wear on any part of the lifter:*
  - Inspect the bail and determine the loss of material that has occurred where the tong interfaces with the hook. The manufacturer will provide a quantifiable value of material loss that is acceptable.
  - Inspect the pins of the tong. Are there wear indications? If there is more than 2 – 5% (obvious indentations), consult the manufacturer about replacement.
  - Inspect the automatic latch. Ensure that there is no peening or wear at the interface between the piston and the catch.
  - Are the pins straight and round? We tend to see deformation of the pins before the links show signs of overloading.
  - Are the bushings in good condition, or are they cracked and worn?
  - Are the legs of the tong straight, and do they meet in the center when the tong is closed?
  - Have any unauthorized modifications been performed on the tong?
  - Are there any cracks of the linkages? A dye-penetrant test may be advisable at areas of high stress or areas where crack propagation is more likely.
  
- *Loose or missing guards, fasteners, covers, stops, or nameplates:*
  - ANSI B30.20 requires that the manufacturer's name and address, serial number, lifter weight, and rated load be affixed to the tong permanently. If a tag is not available, contact the manufacture for a new ID tag.
  - Are the rated load markings on the main structure and visible?
  - Check fasteners, covers and stops to ensure they are properly attached.
  
- *All functional operating mechanisms and automatic hold and release mechanisms for misadjustments interfering with operation.*
  - Operate the grab and verify that it works smoothly. Does the automatic (manual) latch work properly?
  - Do the pads swivel properly (if applicable)?
  - Are the pads or points worn to the extent that they need replacement? It is important that these interface points are maintained since the gripping ratio or coefficient of friction that they create may be a basis of the original design.

All deficiencies should be fully corrected prior to returning the tong to service, and full documentation of the periodic inspection should be maintained for the tong. We would recommend that deficiencies and the resultant corrective maintenance from either a periodic or a frequent inspection be documented, so that a maintenance history of the tong can be tracked.

## **CONCLUSION**

We have tried to outline the type of tongs and some of the design parameters that should be considered when selecting the correct tong for your application. It is vital that, prior to purchasing a tong, you specifically quantify the material that the tong will be handling, the environment in which the tong will operate, and the requirements that the tong will be expected to meet. Armed with this



information, a properly designed tong can be designed and fabricated. With proper operation, maintenance, and inspections, the tong will outlast most other types of material handling equipment in your facilities. The motto of "Keep it Simple" could have been based on the theory, construction and operation of a tong.

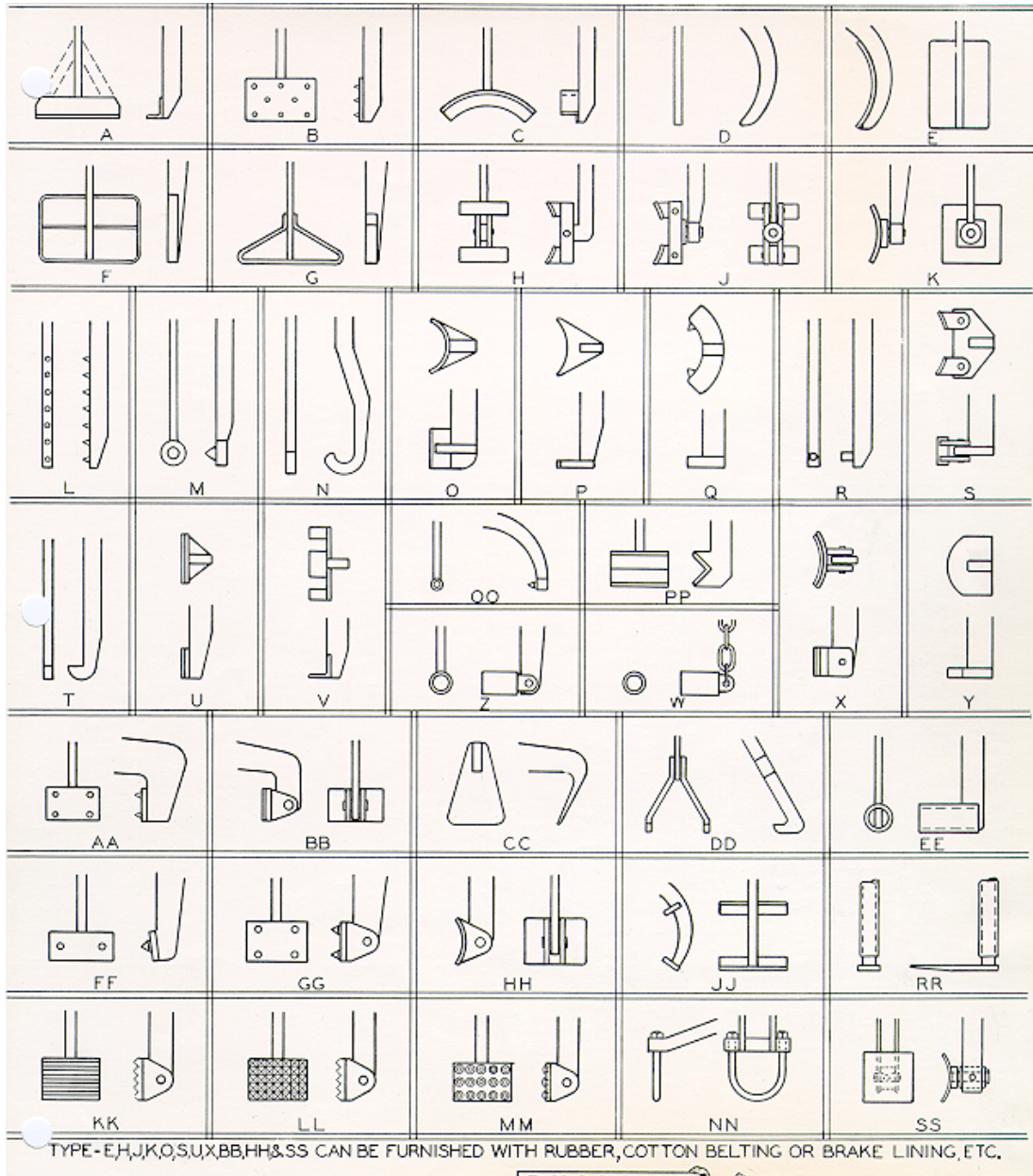

**FIGURE 4**